



Warboy

Product Information Sheet

Standard Specification

Dimensions

| | |
|-----------------------------|-------------------|
| Width/Depth/ (mm) | See product range |
| Height (mm) | See product range |
| Filling inlet diameter (mm) | 50 |
| Tare weight (kg) | See product range |
| Nominal capacity (L) | See product range |

Composition

| | |
|----------------|--------------------|
| Drum | LMDPE ¹ |
| Closure | LMDPE ¹ |
| Closure gasket | See product range |

UN Certification

Group II / SG 1.9

Options

Colour
Various closures
Top print
Side print

¹ – Linear Medium Density Polyethylene

General Description

The Warboy is a re-usable container of double walled construction primarily designed for the transportation and storage of dangerous liquids. The container incorporates an integral ergonomically shaped handling, an offset pouring spout and secure interstacking features. Side walls are provided with large recessed label attachment areas. Considerable attention has been paid to smooth geometry thus ensuring easy cleaning.

The container is rotationally moulded in LMDPE. Unlike blow moulding the process is essentially stress free and creates a container with no seams or welds. The bodies of the mouldings are of generally uniform wall thickness with thickening in corners and radii where reinforcement is of most benefit.

The polymer used in the manufacture of the container is highly UV stabilised and exhibits excellent low temperature impact strength, chemical resistance and ESCR.

The Warboy double walled design is unique. The external drum provides impact protection for the inner drum which contains the product.

The Warboy is not UN restricted to the 5 year service life limit of single walled plastic drums. The Warboy is capable of achieving up to 10 years service life with most products. Francis Ward can advise on service life for your products or you can refer to the **Francis Ward Drum Utilisation Guide**.



Double walled reusable drums for the transportation and storage of dangerous liquids

Models shown are coloured 30L and 45L Warboys with standard closures



Warboy Product Range

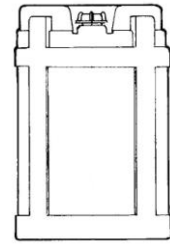
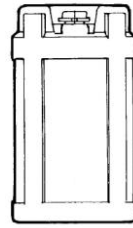

| TYPE | 30L Warboy | 45L Warboy |
|----------------------------|--------------------|--------------------|
| UN Approved | YES (CERT.FW 6040) | YES (CERT.FW 6039) |
| Capacity - L | 30L | 45L |
| Height - mm | 605 | 610 |
| Tare Weight - kg | 4.6 | 6.4 |
| Closure Torque (Nm) | | |
| Standard Cap | 25 | 25 |
| Vented Cap | 25 | 25 |



Coloured 45L Warboys with standard closures

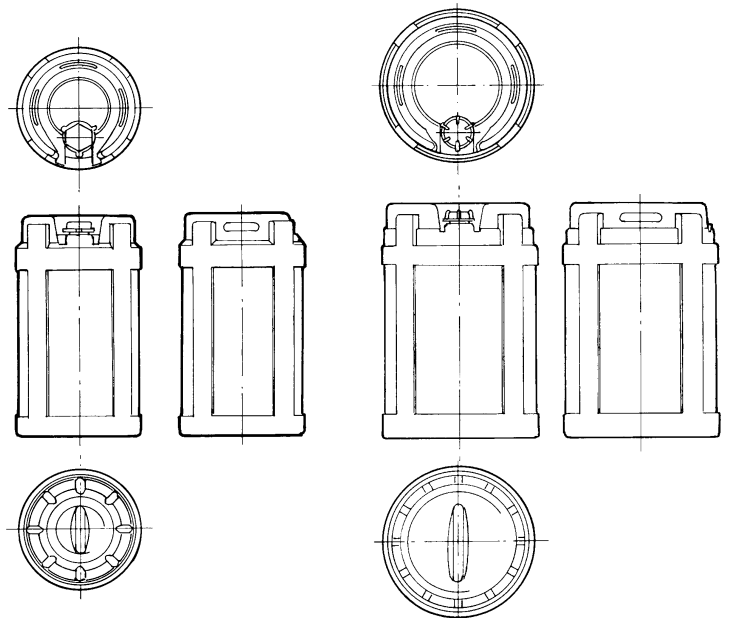

30L Warboy

45L Warboy

Whilst every attempt has been made to ensure that the information provided in this product information sheet is accurate and reliable Francis Ward cannot accept responsibility for the interpretation of the information provided. It is the responsibility of the user to determine the chemical compatibility of the container with its intended contents.



Francis Ward – A Division of The Rotational Mouldings Group

Brook House, 221 Bowling Back Lane, Bradford, BD4 8SJ, UK

Tel: +44 (0)1274 707030 | Fax: +44 (0)1274 724704 | Email: sales@francisward.com | Web: www.francisward.com